

ISSN electrónico: 2172-9077

<https://doi.org/10.14201/fjc2018161130en>

THE MAGIC LANTERN AS A MEANS OF ADVERTISING. HISTORICAL REVIEW OF NEWS, ANECDOTES AND PATENTS

La linterna mágica como soporte publicitario. Recorrido histórico por noticias, anécdotas y patentes

Dra. María Begoña SÁNCHEZ GALÁN.

Profesora Ayudante Doctor. Universidad de Valladolid, España.

mariabegona.sanchez@uva.es

 <https://orcid.org/0000-0002-3578-8446>

ABSTRACT

The magic lantern, a device in which we can find the origins of the current audiovisual culture, was also the cradle of media advertising. During the last decades of the 19th Century, in an attempt to face the growing advertising saturation that was already visible in the daily newspapers press and in the walls of big cities, advertisers, projectionists and a large group of inventors began to turn to the magic lantern as a means for exhibiting all kind of advertisements. In doing so, they wanted to provide advertising with splendor and, besides, to attract the attention of consumers that were immersed in the shift from an agricultural and industrial society to an economy based on consumption. Following a chronological order, this article goes over the different sources in which it is possible to find information about the subject. Through newspapers articles, patents' records and bibliographic references, a timeline is laid down to observe the evolution of the use of magic lanterns for advertising purposes and their promoters' stated intention to link those messages to the leisure and entertainment realms, characteristics that are still alive in the current 21th century advertising.

Key words: magic lantern, media advertising, advertising slides, advertisements, advertising patent, advertising history

RESUMEN

La linterna mágica, artificio en el que encontramos el origen de la actual cultura del audiovisual, fue también la cuna en la que nació y se desarrolló una parte de la publicidad moderna. En el último tercio del siglo XIX, en un intento por salvar la creciente saturación publicitaria que ya se observaba en la prensa diaria y en las paredes de las calles de las grandes ciudades, los anunciantes, los proyccionistas y un nutrido grupo de inventores, comenzaron a recurrir a la linterna mágica como medio para exhibir los anuncios. Buscaban con ello dotar de espectacularidad a la publicidad y atraer la atención de unos consumidores que estaban viviendo en primera persona el paso de una sociedad agrícola e industrial a una economía basada en el consumo. Este artículo repasa de manera cronológica las fuentes de información que hablan de este proceso. A través de artículos de prensa, memorias de patentes y referencias bibliográficas, se establece una línea temporal que permite observar la evolución de las proyecciones publicitarias de linterna mágica y el deseo expreso de sus promotores de vincular sus mensajes al mundo del ocio y del espectáculo, características que permanecen vigentes en la publicidad del siglo XXI.

Palabras clave: linterna mágica, publicidad audiovisual, diapositivas publicitarias, anuncios, patentes de invención publicitaria, historia de la publicidad.

1. INTRODUCTION. RESEARCH OBJECTIVES AND METHODOLOGY

Advertising, interpreted as a means of communication that serves production and consumer capitalism, started to become systematized under the aegis of industrial revolution, and at the same time that steam engines were being developed, together with factories, transportation, new architectural models, shows of image projection, photography, leisure, electricity and cinema. Its history is linked to the history of modern societies, and in those societies advertising found a full range of privileged means to exhibit the discourse of consumerism before an ever increasing audience. The pages of newspapers and magazines, and the walls and façades of buildings —common locations where advertisements and billboards could be seen— were joined, at the end of the 19th century, by train stations, shop windows, magic lantern shows and, afterwards, cinema. The United States —the country in which consumer capitalism developed at the highest pace— showed the entire world the possibilities that advertising offered for business. This path was then followed by the United Kingdom, France, Germany and, to a lesser extent and at a varying rates, by the rest of the countries in Europe.

In the last third of the 19th century, professionals were fully aware of the importance of advertising in the development of commerce and the success of their businesses. Let us consider an example. We are in Spain, in 1876, and in an article called “Crónicas de Filadelfia” [“Philadelphia Chronicles”], José Jordana y Morera tells us about the success that Americans have in their businesses and their tendency to create advertising through all available means, including magic lantern showings:

«Advertising as a means to show and spread the products of our work is here one of the most vital elements to build wealth [...]. Newspapers are the general vehicle for advertising, but there are also thousands of other means and ways to achieve the same goal [...].

The great billboards or signs illuminated by gas or electric light during the night are no longer attracting the attention of passers-by because they are already worn-out. As regards optical effects, one of the newest ones I have seen has been presented before a crowd of onlookers every night for a few days now in Chestnut Street: it is a huge curtain on which, by means of a magic lantern, the industrialist in charge of this brand of night advertising shows different advertisements of other manufacturers and entrepreneurs, alternating large figures with weird and extravagant shapes, with which he passers-by stop on their tracks, captivated by the novelty of this procedure.» (Crónicas, 1876, pp. 214-215).

Bringing this and other references to light and finding out about the role that magic lanterns played in the configuration of modern advertising discourse is the main objective of this research. In our review through the different advertising means that started to be used in the 19th century, the magic lantern played a crucial role, because it was the first device that brought advertising in contact with the screen. This factor is widely known among experts, although it is also true that the literature on this particular phenomenon is not abundant, and it is sometimes difficult to locate. Consequently, it is very difficult to calculate the reach of a resource that, for us, marks the beginning of our current audiovisual advertising. In this article our objective is to review the most relevant available sources and construct with them the history of the relationship between advertising and magic lanterns. We will focus particularly on the presence of this device in Spain, where it seems that the use of a lantern as a means for advertising did not raise the same interest as in the rest of the world.

In order to build this account we have followed the classical structure of historical research and we have done an extensive search of references in the literature, in newspapers and periodicals and in archives. As a result, we have obtained an interesting sample of seemingly unconnected data from different moments and places, which we have integrated into a single narration. The idea behind this is to provide an overview which allows us to observe the phenomenon as a whole; to stop considering that the pieces in this puzzle are isolated manifestations; and to piece them all together and relate the findings with each other in order to see the image they offer. To do so, we have arranged the tiles in this mosaic chronologically. In an early stage we considered other possibilities, such as a geographical or thematic distribution, but those approaches would not let us observe the phenomenon simultaneously within the context of European history. For these reasons, this article includes each reference based on a linear timeline.

This chronological narration begins in the last third of the 19th century and ends in the second decade of the 20th century. This time frame is very significant because, when studying the relationship between magic lanterns and advertising, there is a tendency to include the examples of glass slides and projectors created for cinematographic shows. These glass slides, which were commonly referred to as “advertising slides”, and which remained in use until the second half of the 20th century, were the direct heirs of magic lanterns, but they belong to a different sphere from a conceptual standpoint. Magic lantern shows and cinema have their own characteristics, which are well-delimited, and this factor makes them two different means for advertising. Therefore, our analysis is exclusively limited to the specific case of magic lanterns.

In order to establish an appropriate temporal framework, we have used the periodization proposed by Francisco Javier Frutos and Carmen López (2010), who date the beginning of mass production of magic lanterns in the last quarter of the 19th century, and the beginning of their decline in the first decades of the 20th century. These years coincide with the time in which the consumer society was emerging in developed countries, and it is also the period in which advertising put into practice new commercial and scientific strategies to promote consumerism (Ewen, 1976).

Our narration, for its part, focuses on the sources that refer to advertising as a commercial tool. Nowadays, when we talk about “advertising”, we automatically associate this term with consumerism. This was not the case in the period of our study, and that is why we must be very careful when analyzing the references that emerge when we carry out a search with the term “advertising”. Towards the end of the 19th century, it was common to “advertise” the news, the laws, the decisions of courts or notices, and none of these factors had any relationship with the world of trade. The different meanings of the word “advertising” return documents that must be filtered lest we make a mistake, particularly when the texts refer to “advertising” meant to promote education and exposure to political ideologies, commonly known as “propaganda”. Our account does not dwell on these issues and focuses instead on the use of the magic lantern as a means to advertise consumer goods.

This text is structured around the most important data that we have managed to find, but we wish to believe that there are many more. We trust that new information will arise as the materials waiting their turn in institution archives and periodicals are digitalized and published. This is only the beginning of a story that can still unveil many secrets.

2. FIRST CONTACTS BETWEEN THE MAGIC LANTERN AND ADVERTISING: 1868-1889

Modern advertising shaped itself during the period from the last third of the 19th century to the first third of the 20th century, and it has its origins in mass culture and the effects it had on consumer

culture. During this period, capitalism, which had until then been focused on production, evolved towards more elaborate frameworks in which mass consumption of products became the response to the emerging problems of overproduction that factories were facing. Advertising turned out to be the best tool to promote this change, and the basic principles of advertising theory were developed over that time (Puig, 1986). At the turn of the century, advertising became an important element of economy which, apart from providing information about the new products that could be acquired in the markets, promoted modernity and educated consumers in a new and wide-ranging ideology of “stylistic obsolescence” (Marchand, 1985, p. 156), a phenomenon that forced consumers to constantly replace a product with the latest alternative.

The United States were the country in which the transition from one society to another was most marked. The shift from production capitalism to consumer capitalism took place there between 1890 and 1920 (Ewen, 1976). In Europe, this process was slower due to the different military conflicts that stretched across the continent during that period. In Spain, this social transformation arrived even later, and was not effective until the middle of the 20th century. The predominance of an agricultural society and the outbreak of the Spanish Civil War were the main reasons behind this delay.

However, in all these places, with stronger or weaker markets, the magic lantern collaborated with advertising to promote the new consumer society which would ultimately settle in the Western world. The evolution from one system to another, from production capitalism to consumer capitalism, coincided with industrialization and the mass production and sale of magic lanterns and, afterwards, with their decline and their replacement with cinematographic shows. Javier Frutos and Carmen López, who have researched this phenomenon in depth, claim that in this period there was a “fully developed market for these devices”, and that “magic lantern sessions —either public or private— became an incredibly fertile and diversified industrial activity” (Frutos & López, 2010, p. 27). The success and popularity of this show turned it into an excellent platform for advertising communications.

During the period being discussed here, advertising turned out to be an essential tool for the promotion of products, but it was immediately clear that the pages of newspapers and the walls of cities, which were back then the usual means for the publication of advertisements, were insufficient to meet the demand of an ever increasing number of advertisers. It was necessary to look for new means for commercial communication, and in this context, human billboards appeared, together with advertising vehicles and advertising columns (Eguizábal, 1998, p. 145). This list must also include projection lanterns, which were used to promote goods and services through exhibitions in the streets of the main cities of Europe and the United States.

The oldest known reference in this regard takes us back to 1868. On April 7th of that same year, a man called Lefebvre-Durufilé, who lived in the Rue Vaugirard, in Paris, patented a device for an “application of a magic lantern to advertising through a light source” (Lefebvre-Durufilé, 1868). The name of Lefebvre would appear later on in other similar patents registered in England and was recorded by Hermann Hetch in his book *Pre-Cinema History* (1993). In this same work, we can find the second reference of a document that mentions advertising projections with a magic lantern. It is a patent submitted in England by J. M. A. Lancomme on August 8th 1870, which describes a lantern devised to “exhibit advertising or photographic images” (Hetch, 1993, p. 164). In this device, the slides could be inserted successively or be set on a circular mechanism which, aided by a timer, turned to change the image shown after a pre-established amount of time. Lancomme suggested placing one or two lanterns in a room with the light beam projected outside. In order to capture the image, screens would be installed on the street, in a right angle with the wall, as an imitation of the billboards and signs of the stores. The inventor suggested, at the same time, installing a screen and a projector in a vehicle so that

the advertisements could travel all around the city. Finally, he proposed using his invention to project the images on the façades of theatres and buildings dedicated to variety shows. Lancomme's suggestions included in a single patent, and in a very early period, the different procedures that advertisers would put into practice in the streets of Europe through the next decades.

Clearly, this proposal was meant to provide an answer to a collective concern that inventors of that time were trying to address, and which originated a large number of patents for similar devices. In his work, Hetch includes at least 16 patents which improved minor aspects of advertising projections at the end of the 19th century. Several of these improvements were analyzed by Stephen Herbert in a text called *Lanterns for Advertising*, which includes an illustration of the lantern designed by Lancomme (Herbert, 1997, p. 80). As a result of all these initiatives, devices were built to project advertisements on the streets of several cities in Europe and the United States. Some of these projections were reported, almost as an anecdote, by the newspapers of the time. The oldest piece of news that we can find is quoted in the *Encyclopaedia of the Magic Lantern* (Robinson *et al.*, 2001, p. 10), and it takes us to August 31st 1870. On that day, the newspaper *The Times* published an article called "Sketches from Paris" that mentioned the use of a magic lantern to project advertising images on a shop window in the French capital.

The system must have spread rapidly to other countries, because five years later, in November 1875, Joaquín de Ariza y Carbonell presented in Madrid a request for a privilege to be the sole user of a procedure to "give publicity to advertisements" through a magic lantern, as was done in the United States (Ariza, 1875). Until now, this is the oldest known document related to the use of the magic lantern for advertising purposes in Spain. The file for this request describes in detail the lantern and the procedure. Also, although no patent was requested for this device, Joaquín de Ariza included plans for its installation (Figure 1).

«The objective of Joaquín de Ariza y Carbonell is to introduce in Spain a system that exists in the United States of America to give publicity to the advertisements commissioned to him through a powerful magic lantern, illuminated with Drummond light, that projects signs on a large transparent screen located in some public site and inserts moving shapes, portraits of famous figures and artistic monuments between different advertisements in order to capture the attention of passers-by and, at the same time, to offer them a source of joyful entertainment. This privilege is not intended to exploit the stereopticon or perfected magic lantern illuminated with Drummond light, but only for the advertising system» (Ariza, 1875).

Figure 1. 1875. *Privilege request no. 5370*. Joaquín de Ariza y Carbonell.

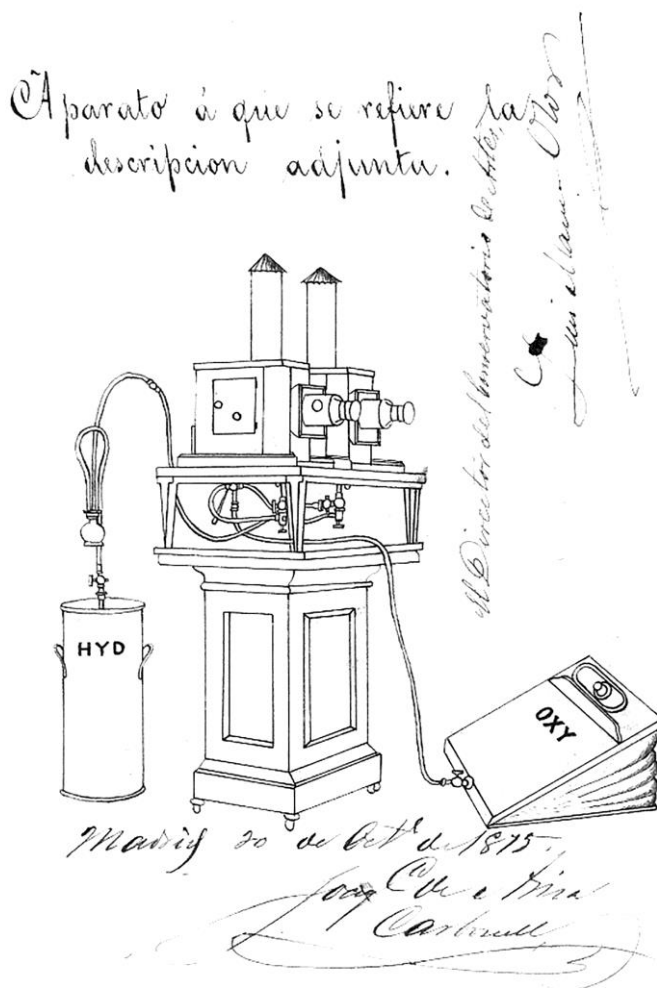

Source: Historical Archives of the Spanish Patent and Trademark Office.

Ariza started this procedure on November 2nd 1875, but the file was finally closed on March 10th 1876, because the formalities required had not been completed and the amount of 750 pesetas to receive the privilege for a period of five years had not been paid. One possible reason for this withdrawal of the claim can be found in a text by María del Carmen Simón Palmer which mentions the refusal of the City Council of Madrid to authorize the new advertising system.

«On February 1st 1876, Joaquín de Ariza, who had obtained a privilege to exploit this system for five years, applied for a license to set up a kiosk in Puerta del Sol or an equivalent location. The City Council rejected this request and claimed that public streets always had to be clear and free for traffic» (Simón, 1977, p. 343).

We can interpret that Joaquín de Ariza did not conclude the procedure because he did not obtain the corresponding license from the City Council of Madrid. Without the expectation to earn an income with the exhibition of advertisements, it made no sense to pay the large sum that was requested to acquire that privilege. Simón Palmer refers to a similar initiative submitted five years later by Fermín Berasategui to the same City Council, but “once again, the city architect presented a report against that permit” (Simón, 1977, p. 344).

Indeed, occupying the streets and hindering traffic were two of the reasons why advertising projections with a magic lantern were mentioned in the newspapers. In our search for information, we have found several news articles related to this aspect. The oldest one was collected by Steven Humphries, who tells us how in 1876, *The Globe* published the news that the traffic in the Strand, in London, had come to a halt due to the exhibition of different dissolving views. According to the article, the images were a facsimile of the posters that could normally be seen in the city (Humphries, 1989, p. 122).

Another reason that took advertising projections to the newspapers was legal lawsuits. On October 28th 1876, the *South Wales Daily News*, in the section of District Intelligence for Cardiff, published a court decision in which a citizen claimed a sum of 24 pounds for rent for the use of a room in Queen Street for the purpose of advertising by means of the magic lantern. The defense was that no rent was due, as the magic lantern advertising business was a partnership affair (District, 1876).

Some years later, on January 26th 1883, the *Edinburgh Evening News* published a press release under the title “Advertising by Magic Lantern” which referred to the legal advice that a London neighbor had requested the previous day at the Street Police Court (Advertising, 1883). In it, the applicant, a cobbler, stated that he had a shop in Tottenham Court Road. His neighbor was a tailor, and he had recently started to project dissolving views through a magic lantern from the second floor of his establishment. This fact attracted a large amount of people who stopped to watch the images in front of the cobbler’s window, and they did not let his customers enter the shop. The police had intervened and had warned the tailor, to no avail. The legal advisor’s response stated that there was a precedent that had taken place some years before, with a similar complaint against a famous watchmaker of the city. His advice was that all the neighbors who had been affected by this should come together and file a class action suit.

Complaints from neighbors and the intervention of the police in advertising projections with magic lantern also reached Paris. In the accident and crime reports section of the newspaper *Gil Blas* of April 13th 1887, we can read:

«La préfecture de police, qui a interdit dernièrement la publicité lumineuse que l’on faisait circuler dans les rues, ferait bien d’interdire la lanterne magique réclame qui est placée près di théâtre des Variétés. Les badaus qui, chaque soir, s’arrêtent près du passage Jouffroy, pour voir cette publicité lumineuse encombrant tellement le trottoir qu’il est absolument impossible de circuler.» (Nouvelles, 1887, p. 1).

The year and place, 1887 and Passage Jouffroy, could be related to a reference that is featured in volume 9 of *Lanterna Magica*, published in Düsseldorf in 1887 and quoted by Hetch (1993, p. 211). That text refers to the projection of advertising on Boulevard Montmartre, in Paris, with humorous images and scenic views inserted between them.

Oddly enough, we have not been able to find any reference in the Spanish press to advertising projections with magic lantern in the country. However, we have found news articles that report the

existence of this activity in other parts of the world. On September 24th 1888, for example, Luis de Llanos, a contributor to *La Vanguardia*, sent a “Letter from Brussels” in which he told the readers that, on his way to Flanders, he had decided to spend a night in Paris. In a rather critical tone, which he used to describe a “decadent”, “poor” and “unwelcoming” city, he said:

«All the rage now is advertising by night with magic lanterns. In a large wall of the boulevard there is a panoramic view of Cairo, then another one with the Parthenon of Athens, then the Courtyard of the Dolls, from Seville, and when the street is crowded with onlookers, enormous advertisements for all kinds of drugs or periodicals start to appear. When the audience —forced to read, much to their regret— starts to break up, the lantern projects again images on the wall [...]. This showing is repeated lots of times” (Llanos, 1888, p. 1).

The use of the magic lantern as an advertising platform must have been a common occurrence in the streets of the main cities of Europe, so much so that it was featured in articles and narrations that had nothing to do with the lantern itself. On March 2nd 1889, for example, the lantern appeared by chance in a news article that talked about the dissolution of the League of Patriots, a French far-right league. The chronicle, published in *La Lanterne: journal politique quotidien*, mentioned different events that had taken place on that day. When describing the evening events, the journalist said:

«Quesques groupes ont stationné devant les bureaux du journal de M. Laguérre. C'étaient des curieux, arrêtés par lanternes magiques réclame qui attire chaque soir les badauds sur certains points du boulevard. Les rassemblements se sont rapidement dissipés. Et vers onze heures, le dernier curieux avait disparu.» (Ligue, 1889, p. 1).

3. NEW SCENARIOS FOR THE PROJECTION OF ADVERTISEMENTS: 1887-1895

The projection of advertising slides with a magic lantern led to the appearance of specific companies dedicated to this activity. Hetch cites the creation in Frankfurt, in 1887, of the Magic Lantern Advertising Company, which sold advertising slides that were alternated with dissolving views (Hetch, 1993, p. 211). Two years later, in September 1889, Wilkinson & Co., a manufacturer of lanterns and slides, sent a letter to the *Optical Magic Lantern Journal and Photographic enlarger* in which he discussed the opportunities to expand that sector and create an agency to centralize the manufacture and distribution of advertising slides. The agency would have branches in the most important cities of the country and would be responsible for drafting contracts with advertisers. Wilkinson & Co. volunteered to carry out those tasks (Hetch, 1993, p. 223).

In that same period, the projection of advertising images entered train stations, a privileged environment for the exhibition of posters. Humphries quotes an article published in 1889 in *The Optical Magic Lantern Journal* that states that the main stations in Great Britain had systems for the projection of advertising with magic lanterns. Advertisements promoted the company itself and showed images of trains and landscapes that changed every 30 seconds thanks to the automatization of the mechanism of the lantern (Humphries, 1989, p. 122).

The first documented reference of projection of advertising slides on the curtains of theaters during the intermissions of performances establishes the beginning of this practice in London in the year 1893 (Hetch, 1993, p. 405). We have found an earlier reference that places this practice in Spain, but

we do not know whether the initiative was ultimately implemented. In July 12th 1892, Fernando Márquez y Anglada filed a patent application in Madrid for the invention of “a system for illuminated advertising on the curtains of theatres”. The report that developed this procedure specified that, during the intermissions of theater performances “a white cloth curtain will be dropped” and “by way of a magic lantern [...] dissolving views will be projected on the curtain [...] and alternated with other images with signs or advertisements” (Márquez, 1892). According to the file of his request, the patent was granted on July 26th of that same year, but there is no record of it ever being implemented.

Humphries mentions that the projection of advertisements on these spaces was common, and he refers to a series of letters in which advertisers complained because the slides were projected before the viewers who occupied the most expensive seats had arrived in the hall, or even before the doors were open to the public (Humphries, 1989, p. 122). These were not the only complaints that reached the press. It seems that advertisers offered their slides for free in exchange for receiving regular reports from projectionists about the frequency with which the images were shown, the amount of people who attended the projections and the social status of the audience. With this information, advertisers attempted to prepare an incipient example of market research. Projectionists, however, were not happy with their end of the deal and would send their complaints to *The Optical Magic Lantern Journal* to protest against the demands of advertisers (Humphries, 1989, p. 127).

The letters received in that publication, in turn, revealed some unexpected uses for the advertising slides for magic lantern. In the year 1893, an Evangelical preacher who used the magic lantern in his talks about moral and abstinence sent a letter to the newspaper with the following message:

«I may say that when I exhibit advertisements slides I always try and point a moral and tell a tale. With ‘The Cabby and his Cocoa’ (Cadbury’s) I say ‘far better to drink cocoa than beer, he is more likely to have his head clear and his feet warm’; with ‘Matchless Cleanser’ that ‘Cleanliness is next to Godliness and if more soap were used there would be less dirt and so on morally’. So you see it is possible to make even this class of advertisement really instructive if pains be taken.» (Humphries, 1989, p. 127).

Back in Spain, on September 13th 1893, Onofre Valdecabres Pechuán, who lived in Valencia, filed a patent request in Madrid for an invention that used the magic lantern for advertising purposes. This request merely claimed the use of “the device of the lantern and other optical devices that project images on any surface in order to show advertisements” (Valdecabres, 1893). The proposal, which did not include any apparent innovation, is very relevant for our research because it is, up to now, the only documented reference to the practical use of the lantern for the projection of advertising in Spain. The file of this patent includes an appendix in which the applicant, on October 14th 1895, proves that “in the city of Valencia, in the Ángeles Street, 1, residence of Elías Martínez Lechón, the device authorized by patent 14,944 was put into practice for its use” (Valdecabres, 1893). We do not have any more information on this topic.

Meanwhile, in January 1894 and in the city of New York, advertising projections with magic lantern took a step forward and chose the clouds as a screen. This event crossed the local borders and was even mentioned in the Spanish newspapers. On Saturday, January 27th 1894, the first page of *El correo Español* showed the following text:

«The citizens of New York received quite a surprise last night when they saw a caption on the clouds that, far from resembling the fateful inscription of Belshazzar's feast, merely praised the superiority of a certain daily newspaper and recommended that everybody should buy it, because it only cost some cents. The principle upon which this effect is based is simple [...]. It is the principle of the magic lantern, but at a huge scale, with a light that has, according to rumor, the power of a million light-bulbs, and that uses the clouds as a cloth to reproduce or paint on them the images of objects. The device is called *cloud projector*; a name which clearly indicates its nature” (Olaeta, 1894, p. 1).

Hetch also includes in his work an event from 1894 in which *The New York Times* projected an advertisement on the clouds (Hetch, 1993, p. 405). It may have been the same event. One year later, the journalist José Echegaray referred to a similar phenomenon in *El Liberal*, published on Thursday, May 23rd 1895. In an article called “Scientific chronicle: Two highly innovative inventions”, the author described a device that was similar to the cloud projector as well as a system to prevent shipwrecks. With regard to the first one, which is relevant to us, the author said:

«We have observed that, after exhausting all surfaces and advertising platforms, someone has recently come up with the idea of projecting advertisements on the sky, or rather, a little bit lower than that, on the clouds that float in the atmosphere [...]. This new invention, this system for advertisements on the clouds, comes from the Chicago Exhibition¹, where every night an electric projector showed the number of visitors to the Exhibition during the day. This plan, once voiced out loud, seems to be the simplest and most natural idea in the world. It is a large-scale magic lantern, with a huge cloth or canvas up there, in space” (Echegaray, 1895, p. 1).

We have not found any reference to this projection in the historical archives of *The New York Times*, in spite of the fact that, oddly enough, two years before the newspaper had published an article with the title “Writing on the clouds” which talked about the success of two experiments carried out in England to project advertisements on the clouds (Writing, 1892). The first demonstration had been produced in London, and the person responsible was Captain Ronald Scott. The second attempt had been performed by Sydney Hodges in the city of Ealing. The article included the opinions of several American scientists who explained the technical feasibility of this procedure.

In the month of March 1895, Alfred Cecil Wright, from Birmingham, filed a patent application in Madrid to register his invention of a “system of a lantern for advertisements” (Wright, 1895). The report describes in detail, with the help of a plan, the characteristics of the lantern that, according to its author, was used to project advertisements (Figure 2).

¹ Held in 1893.

Figure 2. 1895. Patent for an invention 17119. Alfred Cecil Wright.

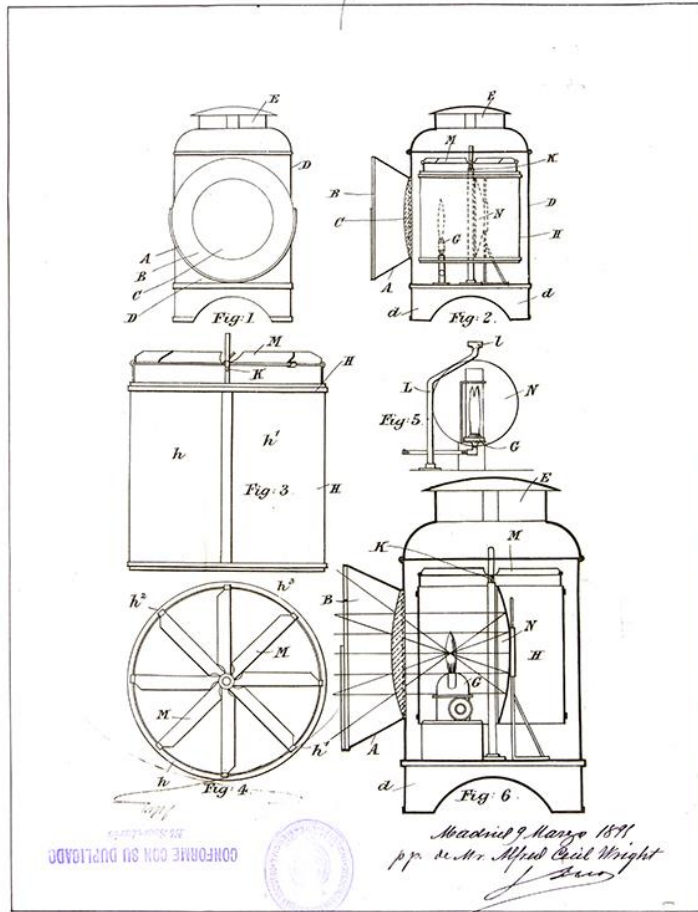

Source: Historical Archives of the Spanish Patent and Trademark Office.

Throughout that same year, advertising slides were projected with a lantern in the Basque Country. José María Unsaín, in the book *El cine y los vascos*, tells us how in the year 1895, the businessman Carlos San Gregorio, owner of the store *Ville de Paris* in Bilbao, advertised his establishment in Correo Street through the projection of advertising slides with a magic lantern (Unsaín, 1985, pp. 35-36).

Sometimes advertisers would make a poor choice when selecting their “screens”; and that led to harsh criticism. Hetch mentions some cases, and he comments the protests caused by advertisement projections on Nelson’s Column and on the outer wall of a church in London in 1895 (Hetch, 1993, p. 405).

In December 1895, the Lumière brothers presented the cinematograph in Paris.

4. ADVERTISING PROJECTIONS WITH MAGIC LANTERN AFTER THE INVENTION OF THE CINEMATOGRAPH. 1895-1920

The cinematograph quickly became part of the list of media that exhibited advertisements, but it did not displace the magic lantern as an advertising platform (Sánchez, 2010). On the contrary, both devices lived together from the start and mixed their messages and their contents. We have found some references that mention this coexistence from a very early period. In December 1897, the “Paris chronicles” signed by Antonio Ambrona in *El álbum americano* said:

«In front of us, on the façade of *Variétés*, different cinematographic views call the attention of a large crowd that applauds this example of scientific progress, this photographic reproduction of life: color and movement.

However, from time to time, the cinematograph gives up its place to the magic lantern, and large illuminated advertisements replace the photographic slides. The audience applauds. The audience has sat through the advertisement, which was the intended objective” (Ambroa, 1897, p. 555).

Although everything seems to indicate that, in Europe, advertising projections were common practice, they must have been rather rare in Spain, because in May 1897 a new patent application was filed in which its author, Leopoldo Murga Machado, from Seville, claimed that he had had “the opportunity to see and appreciate the endless advantages obtained abroad with the system of photographic advertisements with the magic lantern” (Murga, 1897). The application file shows that the patent was not processed.

Shortly afterwards, in November 1899, José Toll presented a new patent application in Barcelona for the invention of a projection system for advertising purposes. According to the summary of the file, it was a “mechanical procedure for the exhibition of advertisements that are projected with light and combined with the exhibition of animated light projections alternated with fixed images” (Toll, 1899). This reference is very significant because it officially announces that the system had been put into practice on February 19th 1902. We have not been able to verify the location or to obtain a description of the procedure due to the poor conditions of the original file, which cannot be consulted. In addition, we have not been able to verify whether the “animated projections” mentioned in the file refer to cinematographic images or to dissolving views.

In March 1899, the British press published again a legal notice which summarized four open cases against an advertising agent, Horace Christopher Crow, who had been accused of collapsing the traffic of the streets of Manchester with comical and advertising images through a magic lantern. The images gathered so many onlookers that the audience was forced to occupy the road and they blocked the passage of vehicles. The accused admitted the facts and, to solve the case, he volunteered to request the assistance of the police if a large crowd of passers-by assembled again. Interrupting the projections was only seen as a last resource (Obstruction, 1899).

Already in the 20th century the cinematograph started to replace magic lanterns in almost all their uses and functions, including advertising. In spite of this fact, lanterns remained alive for a long time and evolved to create a specific platform, that of “advertising slides”, which was in force for several decades. From that moment on, it is virtually impossible to establish a difference between both systems, or to find out which slides were shown with magic lanterns and which were projected with a

cinematograph which was fitted with a mobile device that allowed color filters, lantern images and advertisements to be added.

There are some clear references, such as the ones provided by Santos Zunzunegui who, in his book *El cine en el País Vasco*, talks specifically about the advertising uses of the magic lantern twice. On May 16th 1905, Nicolás Zubieta filed an application in the City Council of Bilbao to request an authorization to project images at the Madrid Shoe Store, which was located on Fueros Street. Two years later, in 1907, the Olimpia Café projected images on a screen located on its roof (Zunzunegui, 1995, pp. 17-18).

There are other cases in which we do not exactly know what equipment was used. From the year 1901, applications filed in Spain to try to patent the procedure of advertisement projection included both systems. That is the case, for example, of the application filed in Madrid on September 9th 1901 by Rafael Marín, who tried to patent “a procedure for portable advertisements with all sorts of colors and shapes using the magic lantern, the cinematograph, and all sorts of devices that can augment objects” (Marín, 1901). The report established that a man would carry any of those devices on his shoulder and project the advertisements on a cloth square, on the walls of houses, or on the floor. Strange as it may seem, the idea that a man would carry an advertising magic lantern on his back had already been patented in England in the year 1896 (Herbert, 1997, p. 85). In Spain, that request was rejected, and yet the description of the system matches the formula of the “sandwich board man/cinematographic poster» that the theoreticians Bori and Gardó included in their review of the advertising platforms available in the 1920s. In the first edition of their *Manual práctico de publicidad* they already described the following procedure:

«a screen on which a device carried on the back of a man projects different advertisements [...]. There is not much visibility, since the effect is reduced by the light of the street. For this reason, this procedure has not been used often, and it was abandoned a short time later» (Bori & Gardó, 1928, vol. II, p. 100).

In the first two decades of the 20th century, other patent requests were presented, and they were also rejected, so we will not discuss them further. In all cases the applicants tried to patent the projection of advertisements without providing technical innovations or specific devices.

Nevertheless, it is worth mentioning the patent request presented in Barcelona in September 1905 by Ángel Fernández Alfageme. The report of this invention proposes “the use of a special advertising system through light projections” which reminds us of the patent presented by Lancomme in England in 1870. The author admits that “similar devices and procedures are already being used” for these purposes and adds that the new lantern has “particular and new” characteristics because “the projections change or are renewed automatically, and they do not need any kind of monitoring or operation for days” (Fernández, 1905). To do so, the inventor suggests that the slides may be fitted in circle, in a turning wheel connected to a clockwork device which would move the wheel at regular intervals (Figure 3). These characteristics could already be seen in Lancomme’s patent (Herbert, 1997, pp. 80).

Yet again, the application report says that the invention was never put into practice, but we also find again a similar description in the publications written by Bori & Gardó, this time in the last edition of the *Tratado Completo de Publicidad y Propaganda*. In this edition of their work, revised in 1936, the authors focused for the first time on the projection of fixed advertising images and they cited several possible systems, including a “disc” or a “wheel on which the slides are placed” (Bori & Gardó, 1936, p. 603). These authors, pioneers in the research of advertising in Spain, did not pay attention to the

projection of fixed advertisements until the third edition of their book, and only as an introduction to a chapter about cinematographic advertising. In the second edition of their work, updated in 1931, they only cited this device in passing when they commented that “there is an advertising based on projections”, which “cannot be considered more than the projection of a poster” (Bori & Gardó, 1931, p. 457). Oddly enough, cinematographic advertisements, which they called “film advertising” were cited in the first edition of their work (Bori & Gardó, 1928, vol. I, p. 30). This finding suggests that magic lantern did not have much success in Spain as an advertising platform.

Figure 3. 1905. Patent for an invention 36742. Angel Fernández Alfageme.

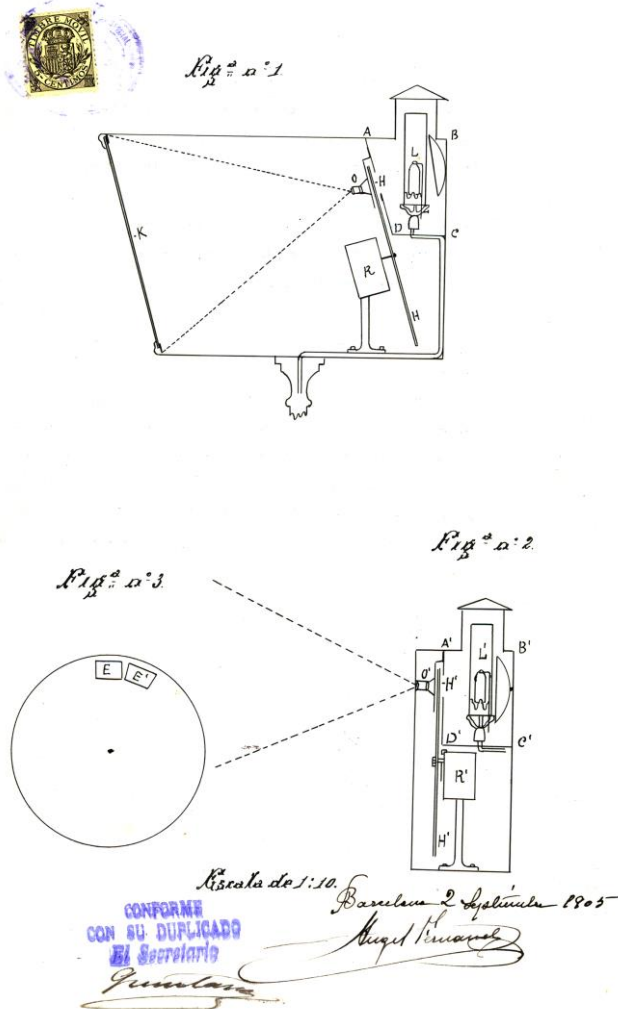

Source: Historical Archives of the Spanish Patent and Trademark Office.

We know that the magic lantern was still used as a projector for advertisements during the first decades of the 20th century, but we have recovered very little information that allows us to come closer to this device during those years. We need to keep searching for data about this period in which

lanterns coexisted with the cinematograph and were used to project advertisements during the intermissions of all kinds of shows. The cinematograph rapidly gained predominance as a mass communication medium, and it gave way to new narrative proposals with their own unique characteristics. Lantern shows progressively disappeared, and only the projector survived as a support and a companion to the cinematograph. That magic lantern, which had almost become an electrical “slide projector”, remained active in the windows of shops and the intermissions of other shows for a long time, and they were used almost exclusively to project advertisements and notices.

Among the advertising uses of the lantern, which was now only seen as a projector for fixed images, we can find a curiosity with which we will put an end to this historical review. In June 1923, Vicente Alonso Mercé and José Antonio García Cassola filed a patent request in Madrid for the “industrial product of an illuminated advertisement obtained through a projection lantern placed on the coaches of underground trains and trams which will show the advertisements on the tunnel walls” (Alonso & García, 1923). The report of the file included a plan that showed the place where the lantern had to be installed to project the advertisements on the underground tunnel walls (Figure 4). The request file says that the system was never put into practice, but Bori & Gardó describe a similar system in the 1931 edition of their *Tratado de publicidad*:

«Recently, a new device has been presented that can only be used in metropolitan trams: the projection of advertisements on the tunnel walls. However, given the speed at which these trams run and their abundant interior lighting, this system is not highly recommended” (Bori & Gardó, 1931, p. 538).

We do not know whether these initiatives had a practical use in the context of Spanish advertising. Some references suggest that they had, and others make us think the opposite. It is necessary to continue this research to cast light on this topic. The review of anecdotes and references that we have been able to identify offers a diffuse image that exists somewhere between the world of anecdotes and that of routine. Sometimes references are made to advertising projections with magic lantern quite naturally, and sometimes the invention is presented as if it were utter madness.

We have reserved a quote for the end of this chapter in which we can see a new example of that delirious normality that surrounds the use of magic lanterns for advertising purposes. They are some words written by Gastón Leroux in “La Mansarde en Or”, a serial published in the Paris newspaper *Le Journal* in 1925. In the issue published on December 11th, as part of a description of the streets of Paris, it says:

«Cela formait un conglomérat informe, une agglutination de matériaux grossiers autour de cette vague image de lanterne magique qu’une publicité obstinée avait fait surgir dans l’obscurité opaque de leurs chambres crâniennes: Paris-la-Nuit!» (Leroux, 1925).

Figure 4. 1923. *Patent for an invention 85998*. Vicente Alonso Mercé and José Antonio García Cassola.

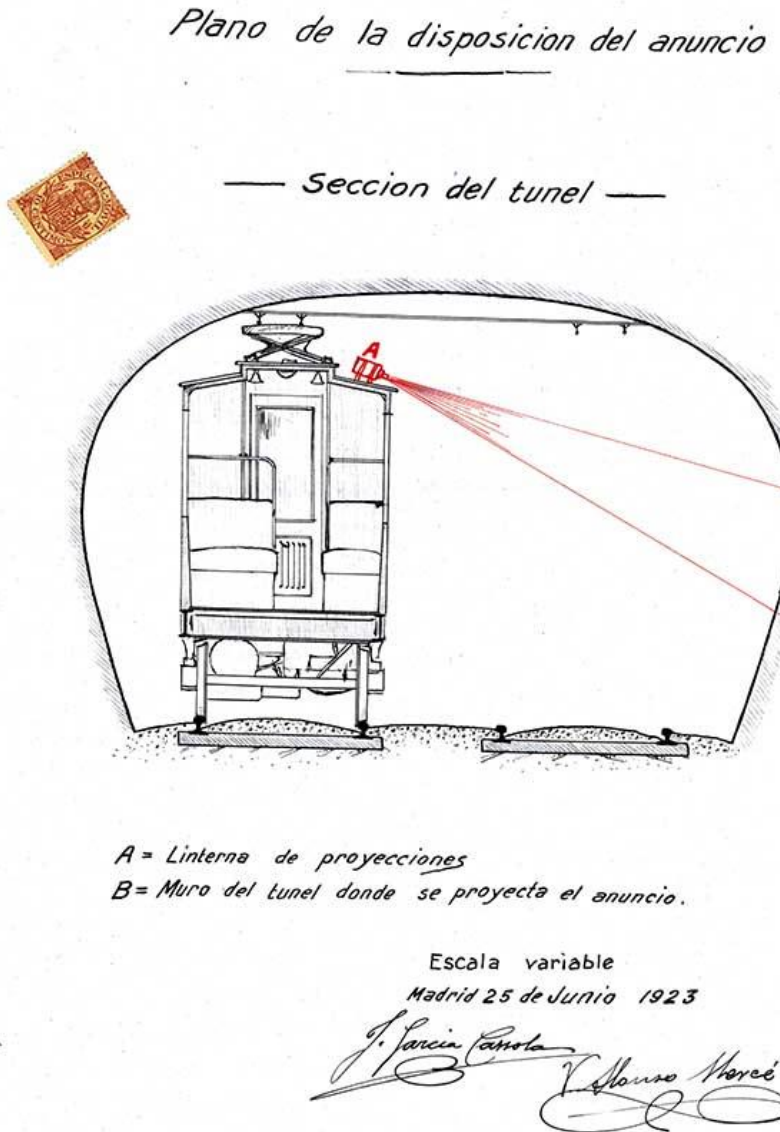

Source: Historical Archives of the Spanish Patent and Trademark Office.

5. CONCLUSIONS

The analysis of the multiple references that we have found lets us deduce that the magic lantern was used as a platform for advertising messages from the last third of the 19th century and that it remained in force until the second decade of the 20th century. Once that lantern shows disappeared, glass slides were developed to create a different specific platform, called “advertising slides”, which had their own unique characteristics and that were directly related to cinematographic audiences and spaces as a medium.

The data collected here make us think that the practice of projecting advertisements through magic lanterns was common in the more developed countries. This activity led to the creation of subsidiary companies and to emerging examples of market research in countries such as Germany and the United Kingdom. In Spain, despite the attempts from businessmen and inventors to imitate a model that was yielding good results in other European Countries, this new platform did not seem to attract the attention of advertisers.

In a first stage, magic lantern projections worked as a platform for exterior advertising, although much more elaborately than was previously thought. Some years ago, and based on the first text published on this topic, we believed that the lantern merely projected copies of advertising posters, but the descriptions that we have been able to read in the chronicles of newspapers and the reports of inventors clearly show that advertising was part of more complex shows that caught the eye of the audience with stories and images that were typical of magic lantern sessions. Advertisements were not the main element there, and they only appeared, with a calculated timing, when the audience was engrossed in the contemplation of other images.

Advertising projections in the specific context of magic lantern sessions are not documented until the decade of 1890, and in this regard, they coincide with the rise of the shows themselves. This is the moment when advertising starts to occupy its own space at the beginning and end of shows, and also during the intermissions.

Advertising projections with a magic lantern were also part of theater shows and, in this case, they followed the same structure that they had in the streets: through sessions of entertainment and leisure with interspersed advertisements.

These conclusions show that magic lanterns were the origin of our current audiovisual advertising, in which advertisements are inserted in entertainment shows and in which specific contents are created so that the narration naturally embraces the advertising message. The magic lantern, as an advertising platform, is therefore shaped as a clear predecessor of the current patterns in advertising for show business.

These characteristics are even more evident when the contents of the advertising slides for magic lantern that have survived are analyzed. This line of research, which has intentionally been left outside of the scope of this study, offers a vast range of possibilities which will be discussed in other studies.

In addition, we have not approached the study of other optical systems used in the 19th century as an advertising platform. Their analysis can yield some interesting results. We would not wish to finish this article without providing one example. To do so, we can look at the patent application presented in Barcelona in May 1904 by José Barberá Humbert and Domingo Maña Solé, in which they intended to use stereoscopic images as a vehicle for advertising (Barberá & Maña, 1904). The main advantage of this system, according to its inventors, was the practice of collecting, which would multiply the effectiveness of the advertisement through the years (Figure 5). They were not mistaken, because collectors have been responsible for preserving many of the images and devices that we are studying today.

The magic lantern and optical devices of what we know as the “pre-cinema” era were the gateway to modernity. The vital role played by these devices as a vehicle for new proposals and ideologies has been severely underappreciated. Rather than being mere scientific curiosities, toys or experiments, this projection equipment paved the road for an entire world of scientific, academic, commercial and political proposals that shaped the economic and social models of the 20th century. The texts that we have reviewed show the concerns of a society that walked towards the future and in which advertising and consumerism emerged as elements that would shape the new social structure.

Figure 5. 1904. Patent for an invention 34022. José Barberá Humbert and Domingo Maña Solé.

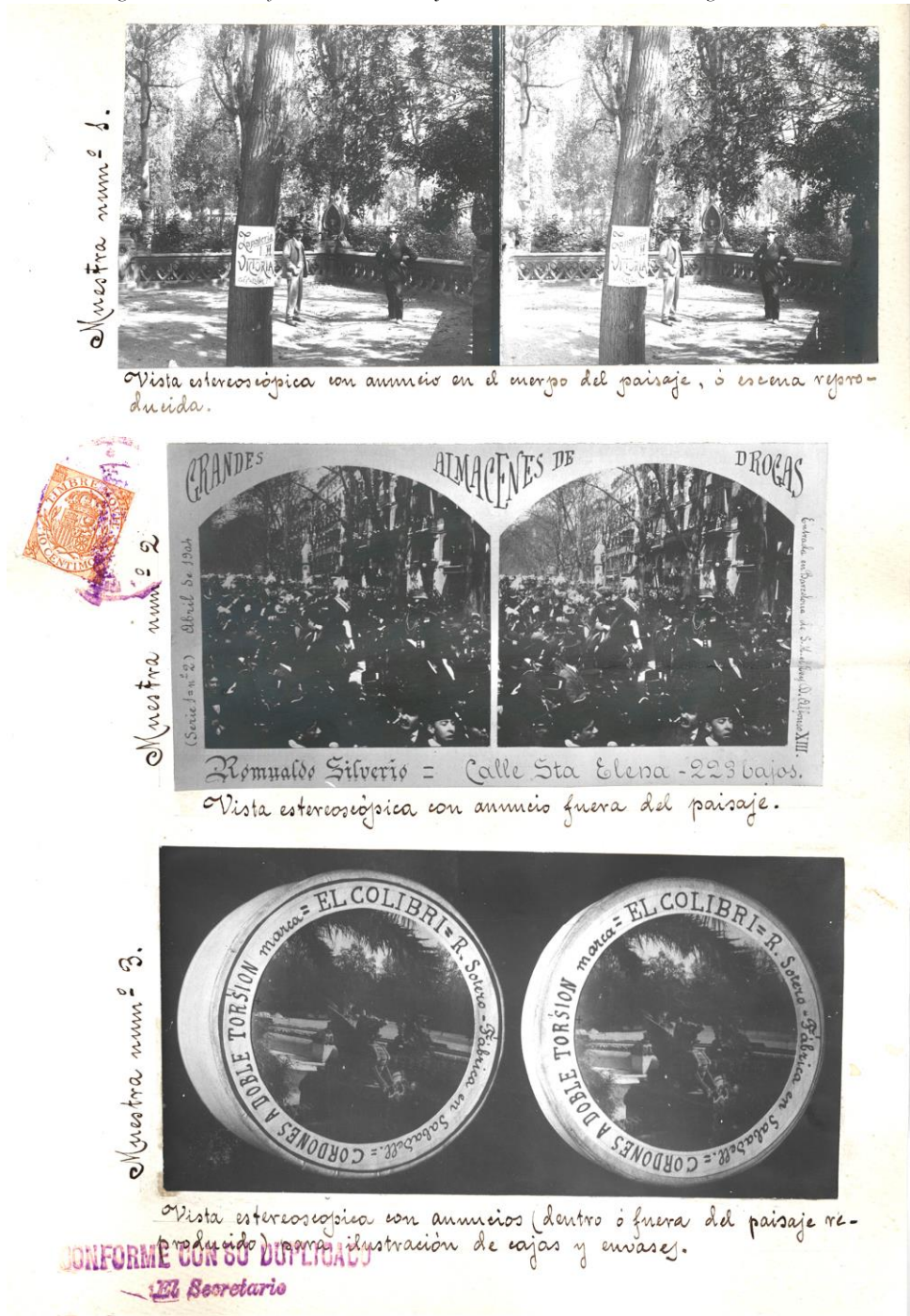

Source: Historical Archives of the Spanish Patent and Trademark Office.

Finally, we want to invite our readers to visit the online resources that reproduce the advertising slides for magic lantern. Some examples can be found in the tools that the project “A Million Pictures” offers to researchers. The repository “Lucerna”² and the application “Linternauta”³, apart from providing additional literature references, show images of glass slides with advertising content. We want to recommend that our readers visit the website “De Luikerwaal”, managed by Henc R. A. de Roo, a pioneer in the diffusion of the history of the magic lantern⁴. The advertising glass slides included in the site are extremely beautiful.

In this text we have merely pointed out facts, dates and references, but a detailed analysis of each of the references in our list can offer many other interpretations and cast light on a multitude of different perspectives. We trust that some of these data will be an inspiration for new research and that this is only the beginning of a larger road through the multiple stories that magic lanterns still have to tell.

6. REFERENCES

- Advertising (1883). Advertising by Magic Lantern. *The Edinburgh Evening News*. Friday January 26, 1883, 4.
- Alonso Mercé, V. & García Cassola, J.A. (1923). *Patente de Invención 85998*. Madrid, 30 June, 1923. Archivo Histórico de la Oficina Española de Patentes y Marcas (OEPM).
- Ariza Carbonell, J. (1875). *Privilegio de Introducción 5370*. Madrid, 2 de noviembre de 1975. Archivo Histórico OEPM.
- Barberá Humbert, J. & Maña Solé, D. (1904). *Patente de Invención 34022*. Barcelona, 18 May 1904. Archivo Histórico OEPM.
- Bori R. & Gardó J. (1928) *Manual Práctico de Publicidad*. Volumen I y II. Barcelona: Editorial Cultura.
- Bori R. & Gardó J. (1931) *Tratado completo de publicidad y propaganda*. Barcelona: José Montesó Editor.
- Bori R. & Gardó J. (1936) *Tratado completo de publicidad y propaganda*. Barcelona: José Montesó Editor.
- District (1876). District Intelligence, Cardiff. Country Court. *South Wales Daily News*, Saturday October 28, 1876, 6.
- Echegaray, J. (1895) Crónica científica. Dos inventos novísimos. *El Liberal*, 5711. Madrid, jueves 23 de mayo de 1895, 1.
- Eguizábal, R. (1998). *Historia de la publicidad*. Madrid: Eresma y Celeste Ediciones.
- Ewen, S. (1976). *Captains of consciousness: Advertising and the social roots of the consumer culture* New York: M Graw Hill.
- Fernández Alfageme, A. (1905). *Patente de Invención 36742*. Barcelona, 2 September 1905. Archivo Histórico OEPM.
- Frutos Esteban, F.J. & López San Segundo C. (2010). La vuelta al mundo de la linterna mágica en ochenta vistas. *Fonseca. Journal of Communication*, 1, 1-32.
- Frutos Esteban, F.J. (2008). La linterna mágica: de la invención a la decadencia (siglos XVIII-XX). *Historia Contemporánea* 36, 9-32.
- Herbert, S. (1997). Lanterns for Advertising. In Crompton D., Franklin R. & Herbert S. (eds.). *Servants of Light: the book of the lantern*. London: Magic Lantern Society, 80-85.
- Hetch, H. (1993). *Pre-Cinema History. An Encyclopaedia and Annotated Bibliography of the Moving Image Before 1896*. London: British Film Institute.

² <https://www.slides.uni-trier.de/index.php>

³ <http://linternauta.docenciavirtual.es/>

⁴ <https://www.luikerwaal.com/index.htm>

- Humphries, S. (1989). The Hard Sell. In Humphries, S, *Victorian Britain Through the Magic Lantern*. Londres: Sidwick & Jackson, 121-131.
- Jordana y Morera, J. (1876). Crónicas de Filadelfia. *Revista de España*, 50. Madrid, May-June 1876, 212-223.
- Lefebvre-Durufié (1868). Brevet 80372. Paris, 7 avril 1868. *Bulletin des lois de la République Française*, XII Série de 1872. Paris: Imprimerie Nationale, 1873, p. 238.
- Leroux, G. (1925). La Mansarde en Or. *Le Journal*. Paris, 11 December 1925, 2.
- Ligue (1889). Ligue des patriotes. *La lanterne: journal politique quotidienne*, 4333. Paris, Sat., 2 March 1889, 1.
- Llanos, L. (1888). Carta de Bruselas. *La Vanguardia*, 452. Barcelona, Mon., 24 September 1888, 1.
- Marchand, R. (1985). *Advertising the American Dream. Making way for modernity. 1920-1940*. Los Angeles: University of California Press.
- Marín, R. (1901). *Patente de invención 28476*. Madrid, 9 September 1901. Archivo Histórico OEPM.
- Márquez y Anglada, F. (1892). *Patente de Invención 13535*. Madrid, 12 July 1892. Archivo Histórico OEPM.
- Müller-Kolb, D. (2015). Advertising with Light. Commerce and the Magic Lantern. *The magic lantern: number 2*, 6-8.
- Murga Machado, L. (1897). *Patente de Invención 20915*. Sevilla, 26 May 1897. Archivo Histórico OEPM.
- Nouvelles (1887). Nouvelles et Echos. Aujourd'hui. *Gil Blas*, 2763. Paris, Wed. 13 April 1887, 1.
- Obstruction (1899). Obstruction Case. *The weekly Standard and Express*. Saturday, March 25, 1899, 6.
- Olaeta (1894). Nuevo modo de anunciar. *El correo Español: diario tradicionalista*, 1615. Madrid, Sat. 27 January 1894. 1-2.
- Puig, J.J. (1986). *La publicidad: historia y técnicas*. Barcelona: Ediciones Mitre.
- Robinson, D. Herbert, S. & Crangle R. (2001). *Enciclopedia of the Magic Lantern*. London: Magic Lantern Society.
- Sánchez Galán, M.B. (2010). La publicidad y la imagen en movimiento. Primeros pasos del cine publicitario en España. *Pensar la Publicidad*, vol. 4-1, 79-96
- Sánchez Galán, M.B. (2003). Usos publicitarios de la linterna mágica. In Quintana A. *Imatge i viatge. De les vistes òptiques al cinema: la configuració de l'imaginari turístic*. Girona: Fundació Museu del Cinema. Col·lecció Tomàs Mallol, Ajuntament de Girona y Universitat de Girona, 175-180.
- Shudson, M. (1993). *Advertising, the uneasy persuasion*. London: Routledge.
- Simón Palmer, M.C. (1977). La publicidad en las calles madrileñas durante el siglo XIX. *Anales del Instituto de Estudios Madrileños*. Tomo XIV. Madrid: CSIC.
- Toll, J. (1899). *Patente de Invención 25129*. Barcelona, 30 November 1899. Archivo Histórico OEPM.
- Unsaín, J.M. (1985). *El cine y los vascos*. San Sebastián: Editorial Eusko-Ikaskuntza. Sociedad de Estudios Vascos.
- Valdecabres Pechuán, O. (1893). *Patente de Invención 14944*. Valencia, 13 September 1893. Archivo Histórico OEPM.
- Zunzunegui, S. (1995). *El cine en el País Vasco*. Diputación Foral de Vizcaya.
- Wright, A.C. (1895). *Patente de Invención 17119*. Madrid, 9 March 1895. Archivo Histórico OEPM.
- Writing (1892). Writing on the clouds. *The New York Times*, New York, December 25, 1892.